

App Note 302: DS2141, DS21Q41, DS21Q43 8-MHz System Clock Operation

The DS2141, DS21Q41, DS21Q43, DS2151 and DS2153 PCM signals can interface to an 8 MHz system backplane. Typically this application is used to multiplex four 2.048 MHz PCM streams onto a single 8 MHz PCM stream. To accomplish this the elastic stores are enabled and placed in the 2.048 MHz SYSCLK mode. Figure 1 describes a timing scheme in which a single RSYNC is generated for all four framers. Each framer in turn is driven with an 8.192 MHz clock burst of 8 cycles. Each clock burst causes the elastic store to output 1 DS0. This results in a Byte Interleaved 8.192 MHz PCM stream.

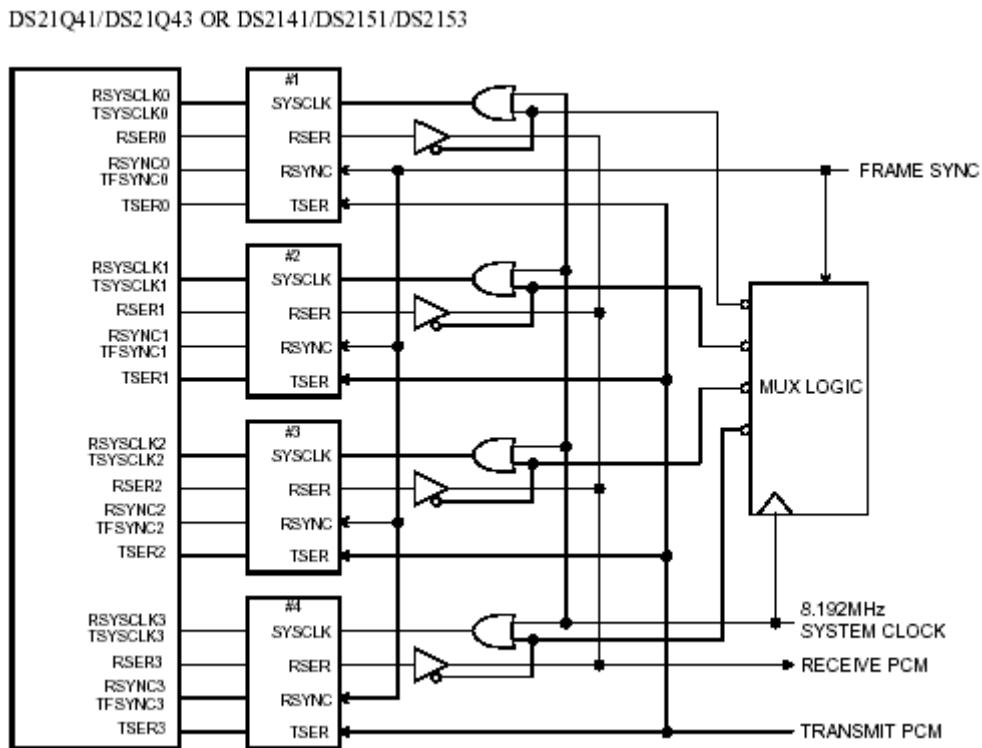

Figure 1. Quad Multiplexed Frames